

BI-METAL THERMOMETERS

Adjustable Angle



Model L
3" Diameter Head
with Calibrator

Model J
5" Diameter Head
with Calibrator

FEATURES

- Type 304 stainless steel.
- All welded construction.
- Easy to calibrate.
- Dial printed with large black numbers and graduations - easy to read from any angle.
- Hermetically sealed per ASME B40.3
- Connection nut: 1/2" NPT. Can be supplied with Union Connection or other NPT sizes at extra charge.
- Stem diameter: 1/4".
- Standard stem lengths (including threads): 2 1/2", 4", 6", 9", 12", 15", 18" and 24". Available in stem lengths up to 72".
- Actuated by super-sensitive bi-metallic Helix Coil.
- Bi-metal element dampened with silicone for minimum vibration and maximum heat transfer.
- Accuracy to within ±1% total scale range.
- Over-range protection: 50% up to 500°F, 10% above 500°F.
- Extra heavy glass crystal. Plastic or tempered crystal available..
- Silicone filling available for vibration dampening.

ORDERING INFORMATION

1. Model Number.
2. Temperature Range
3. Stem Length.
4. Connection Nut Size.
5. Accessories Required
6. Any application other than normal, such as over-range, high pressure or corrosive conditions. Give details.
7. If Head is subjected to temperatures in excess of 300°F, state temperature.

Shipping Weights:

Model L 1 lb.

Model J 2 lbs.

Example: L-12(50-400C) = Model L, 12" Stem, 50 to 400° Celsius.

Temperature Ranges					
Fahrenheit	°/Div.	Celsius	°/Div.	Dual	
				°F	°C
-100° to 100°	2°	-70° to 70°	1°	-100/100	-70/40
-40° to 160°	2°	-40° to 70°	1°	-40/160	-40/70
*25° to 125°	1°	0° to 50°	.5°	25/125	-5/50
0° to 200°	2°	0° to 100°	1°	0/200	-10/90
0° to 250°	2°	-20° to 120°	2°	0/250	-20/120
20° to 240°	2°	-10° to 110°	1°	20/240	-10/115
50° to 300°	2°	0° to 150°	1°	50/300	10/150
50° to 400°	5°	0° to 200°	2°	50/400	10/200
50° to 500°	5°	0° to 250°	2°	50/500	10/260
100° to 800°	5°	50° to 400°	5°	150/750	70/400
**200° to 1000°	10°	**100° to 500°	5°	**200/1000	100/500

* Minimum Stem, 4"

** Not recommended for continuous use above 800°F or 425°C

• Additional dial ranges and stem lengths available

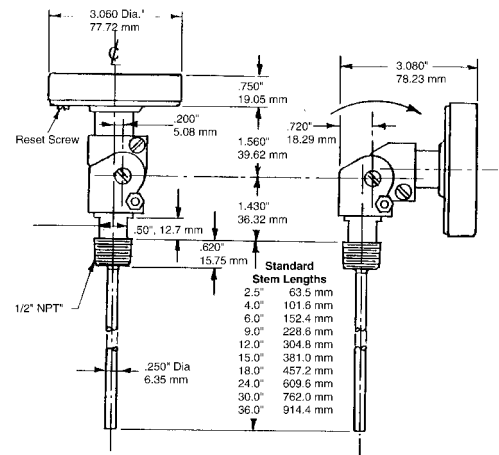

Model L

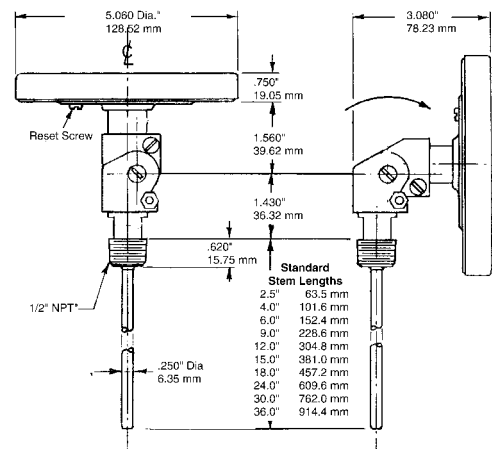

Model J